

PARTS LIST					
ITEM	PART NUMBER	QTY	TITLE	DESCRIPTION	MASS
1	TS3670-000A-001	1	BTM CONVEYOR ASSEMBLY	ASSEMBLY	10944.816 lbmass
2	TS3670-000B-001	1	MID CONVEYOR ASSEMBLY	ASSEMBLY	10265.060 lbmass
3	TS3670-000C-001	1	TOP CONVEYOR ASSEMBLY	ASSEMBLY	10953.578 lbmass

QTY : 1

WEIGHTS
TOTAL : 32,164 LBS
AXLE : 18,862 LBS
FIFTH WHEEL : 13,301 LBS

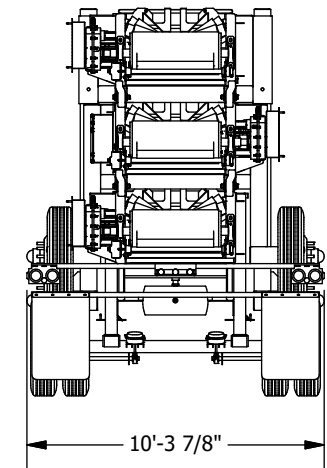
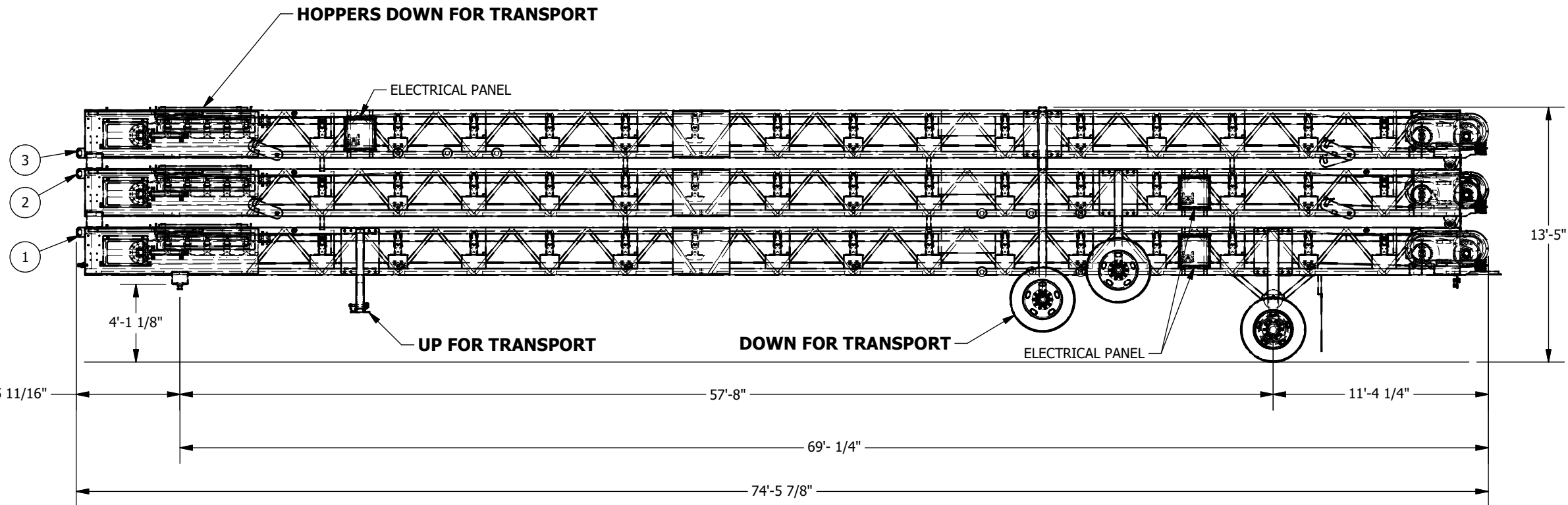
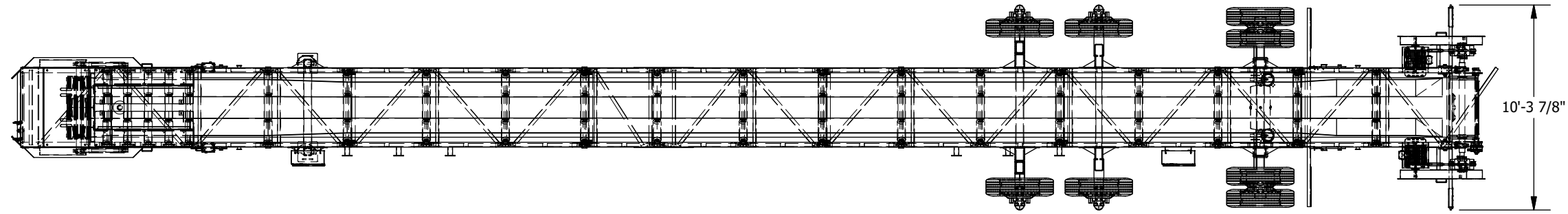
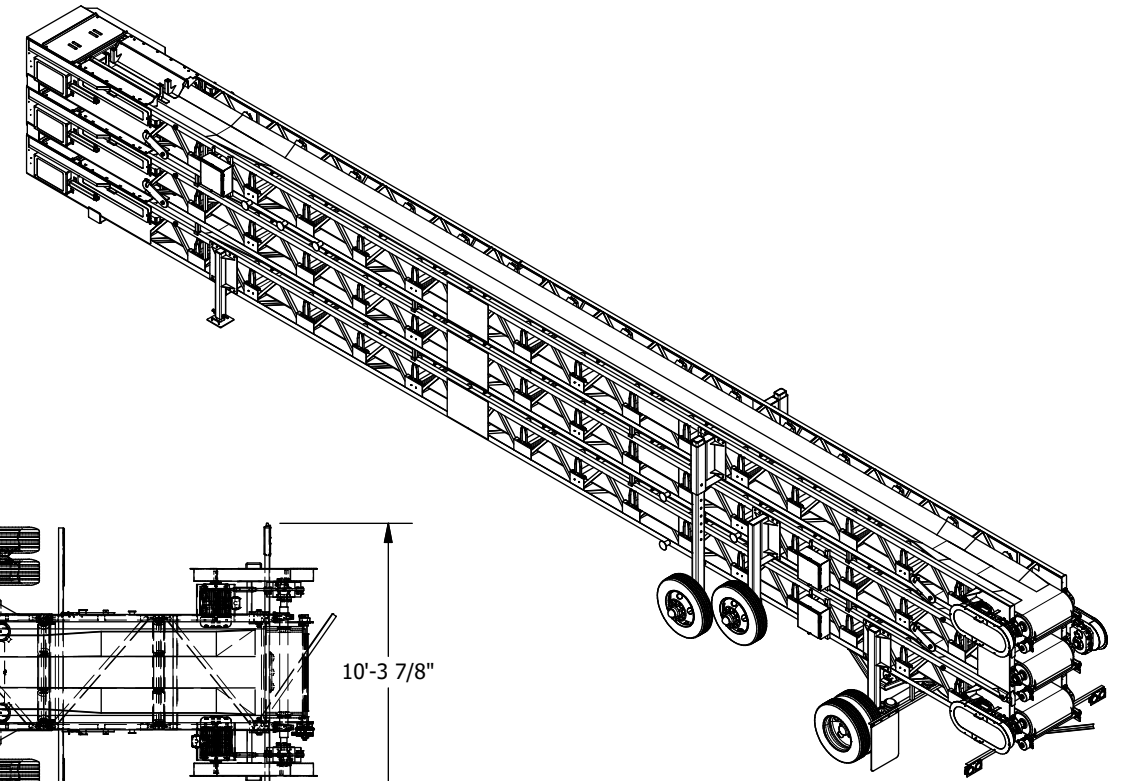

36" X 70' TRIPLE STACK ASSEMBLY	DWG # : TS3670-000-001
P.O. BOX 306 WALNUT, IL 61376 (815) 379-2090	
DETAIL: JLB	
DESIGN: JLB	
32163.5 lbmass	
SIZE: B	
SHEET: 1 OF 1	
DATE: 9/29/2021	